



Ref. T1/2.03

MSC.1/Circ.1281  
9 December 2008

**EXPLANATORY NOTES TO THE INTERNATIONAL CODE  
ON INTACT STABILITY, 2008**

1 The Maritime Safety Committee, at its eighty-fifth session (26 November to 5 December 2008), adopted, by resolution MSC.267(85), the International Code on Intact Stability, 2008 (2008 IS Code). In adopting the 2008 IS Code, the Committee recognized the necessity of appropriate explanatory notes to ensure uniform interpretation and application.

2 To this end, the Committee approved the Explanatory Notes to the Intact Stability Code, 2008, set out in the annex, as prepared by the Sub-Committee on Stability and Load Lines and on Fishing Vessels Safety, at its fiftieth session (30 April to 4 May 2007).

3 The Explanatory Notes are intended to provide Administrations and the shipping industry with specific guidance to assist in the uniform interpretation and application of the intact stability requirements of the 2008 IS Code.

4 Member Governments are invited to use the Explanatory Notes when applying the intact stability requirements of the 2008 IS Code adopted by resolution MSC.267(85) and to bring them to the attention of all parties concerned.

\*\*\*



## ANNEX

EXPLANATORY NOTES TO THE INTERNATIONAL CODE  
ON INTACT STABILITY, 2008

## CONTENTS

<b>CHAPTER 1 – GENERAL</b> .....	2
1.1 Introduction .....	2
1.2 Purpose .....	2
 <b>CHAPTER 2 – TERMINOLOGY</b> .....	 2
 <b>CHAPTER 3 – ORIGIN OF PRESENT STABILITY CRITERIA</b> .....	 4
3.1 General .....	4
3.2 Background of criteria regarding righting lever curve properties (part A of the 2008 IS Code) .....	5
3.3 Background of the approximate formula for the minimum $GM_0$ for small fishing vessels (part B, paragraph 2.1.5.1 of the 2008 IS Code) .....	16
3.4 References relating to paragraphs 3.1 to 3.3 .....	19
3.5 Background of the severe wind and rolling criterion (weather criterion) .....	20
3.6 References relating to paragraph 3.5 .....	28
 <b>CHAPTER 4 – GUIDANCE FOR THE APPLICATION OF THE 2008 IS CODE</b> ....	 29
4.1 Criteria regarding righting lever curve properties .....	29

## **EXPLANATORY NOTES TO THE INTERNATIONAL CODE ON INTACT STABILITY, 2008**

### **CHAPTER 1 – GENERAL**

#### **1.1 Introduction**

The intact stability criteria given in part A (mandatory) and part B (recommendatory) of the 2008 IS Code are prescriptive rules developed from ship operation statistics and weather criterion collected in the middle of the twentieth century. To enable a proper understanding and application of these criteria, their origin and development are presented in chapter 3.

#### **1.2 Purpose**

The purpose of these explanatory notes is to deliver to the user of the Code information on the history, background and method of elaboration of the present stability criteria, as set out in part A of the 2008 IS Code.

### **CHAPTER 2 – TERMINOLOGY**

It should be noted that, while the terms listed below are in common usage, they are not those given in MSC/Circ.920, MODEL LOADING AND STABILITY MANUAL, section 2.2, table 1, which are based on ISO standards (ISO 7462 and ISO 7463).

Particular care should be taken with regard to asymmetric weight and buoyancy distribution.

<b>Term, as used in the 2008 IS Code</b>	<b>Term, as used in MSC/Circ.920</b>	<b>Explanation</b>
LCG	XG	<b>Longitudinal Centre of Gravity (m from A.P.)</b> Longitudinal distance from reference point to centre of gravity, reference point usually at Aft Perpendicular (forward + / aft -).
TCG	YG	<b>Transversal Centre of Gravity (m from C.L.)</b> Transversal distance from reference point to centre of gravity, reference point on the Centreline (port + / starboard -).
VCG	KG	<b>Vertical Centre of Gravity (m above B.L.)</b> Vertical distance from reference point to centre of gravity, reference point on Base Line (upwards + / down -).
LCB	XB	<b>Longitudinal Centre of Buoyancy (m from A.P.)</b> Longitudinal distance from reference point to centre of buoyancy, reference point usually at Aft Perpendicular (forward + / aft -).
TCB	--	<b>Transversal Centre of Buoyancy (m from C.L.)</b> Transversal distance from reference point to centre of buoyancy, reference point on the Centreline (port + / starboard -).
VCB	--	<b>Vertical Centre of Buoyancy (m above B.L.)</b> Vertical distance from reference point to centre of buoyancy, reference point on Base Line (upward + / down -).
LCF	XF	<b>Longitudinal Centre of Flotation (m from A.P.)</b> Longitudinal distance from reference point to centre of flotation, reference point usually at Aft Perpendicular (forward + / aft -).
TCF	--	<b>Transversal Centre of Flotation (m from C.L.)</b> Transversal distance from reference point to centre of flotation, reference point on the Centreline (port + / starboard -).

In all cases it is of utmost importance to define clearly the reference points/planes and the signs of the positive and negative directions along the vessel's coordinate system.

## CHAPTER 3 – ORIGIN OF PRESENT STABILITY CRITERIA

### 3.1 General

3.1.1 The Maritime Safety Committee requested the Sub-Committee on Stability and Load Lines and on Fishing Vessels Safety (SLF), to develop a range of intact stability requirements to cover all ship types for eventual incorporation into the 1974 SOLAS Convention. At the thirty-third session of the Sub-Committee (SLF 33), the Working Group on Intact Stability (IS) considered this matter and foresaw the procedural problems that would arise by incorporating a wide range of stability criteria covering different ship types into the Convention, and also recognized that these criteria could not be developed in a short time. The group recommended that, alternatively, consideration should be given to developing a comprehensive code to incorporate the then existing stability requirements contained in all IMO recommendations and codes for various types of ships. Criteria for additional ship types could be added later as each ship type was considered and a criterion developed. The group also suggested that the 1974 SOLAS Convention should either: include a basic stability standard and refer to the Code for varying ship types or, alternatively, it should only refer to the Code. The proposed Code could be divided into two parts: part A, containing mandatory requirements; and part B, containing recommendatory requirements. Development of the proposed Code was given priority [IMO 1988].

3.1.2 In considering the proposal by the above group, SLF 33 agreed that the development of a stability code for all ships covered by IMO instruments (IS Code) would be of value, so that the generally accepted and special stability requirements for all types of ships' forms would be contained in a single publication for ease of reference. This was thought to be important because stability requirements were dissipated amongst various documents which made their use by designers and authorities difficult [IMO 1988a]. The SLF Sub-Committee emphasized that the Code should contain instructions on operational procedures as well as technical design characteristics. This course of action was approved by the Maritime Safety Committee at its fifty-seventh session.

3.1.3 The collation of the stability requirements contained in various IMO instruments and the preparation of the first draft of the Code was undertaken by Poland and submitted to IMO [IMO 1990]. This formed the basis for the development of the Code which was to include the following groups of requirements as proposed by Poland [Kobylnski 1989]:

- .1 ship construction;
- .2 physical characteristics of ships;
- .3 information available onboard and navigational aids; and
- .4 operations.

3.1.4 This framework was eventually adopted by SLF 35, which also agreed that the Code should have recommendatory status. The final draft of the Code was agreed by SLF 37 and subsequently adopted by resolution A.749(18) [IMO 1993]. It was subsequently amended in 1998 by resolution MSC.75(69). The Code was considered to be a "living" document under constant review, into which all new requirements developed by IMO would be incorporated.

## **3.2 Background of criteria regarding righting lever curve properties (part A of the 2008 IS Code)**

### **3.2.1 Introduction**

3.2.1.1 The statistical stability criteria were originally included in resolutions A.167(ES.IV) and A.168(ES.IV). They were developed as a result of discussions conducted at several sessions of the Sub-Committee on Subdivision and Stability Problems (STAB), a forerunner of the SLF Sub-Committee and the Working Group on Intact Stability (IS). There was general agreement that the criteria would have to be developed on the basis of the statistical analysis of stability parameters of ships that had suffered casualties and of ships that were operating safely.\*

3.2.1.2 The IS Working Group agreed to a programme of work that eventually included the following item:

- .1 collation, analysis and evaluation of existing national rules or recommendations on stability;
- .2 evaluation of stability parameters which could be used as stability criteria;
- .3 collection of stability characteristics of those ships that become casualties or experienced dangerous heeling under circumstances suggesting insufficient stability;
- .4 collection of stability characteristics of those ships which were operating with safe experience;
- .5 comparative analysis of stability parameters of ships becoming casualties and of ships operated safely;
- .6 estimation of critical values of chosen stability parameters; and
- .7 checking formulated criteria against a certain number of existing ships.

3.2.1.3 The analysis of existing national stability requirements (paragraph 3.2.1.2.1) [IMO 1964] revealed considerable consistency in the applicability of certain parameters as stability criteria. It was noted also that in many countries there was a tendency to adopt weather criterion. However, weather criterion was not considered by the IS Working Group at that time.

3.2.1.4 With regard to paragraph 3.2.1.2.2 of the programme, the IS Working Group singled out a group of parameters characterizing the curve of righting levers for the ship at rest ( $V = 0$ ) in still water. This was done notwithstanding the fact that if a ship sails in a seaway, the curve of static stability levers changes. However, it was decided that the only practical solution would be to use the “stipulated” curve of righting levers and this curve could be characterized using the following set of parameters:

---

\* The detailed discussion of the work of these IMO bodies and of the method used in the development of stability standards was reported in the following papers: Nadeinski and Jens [1968] and Thompson and Tope [1970].

- .1 initial stability –  $GM_0$ ,
- .2 righting levers at angles –  $GZ_{10}, GZ_{20}, GZ_{30}, GZ_{40}, GZ_{\varphi}, GZ_m$ ,
- .3 angles –  $\varphi_m, \varphi_v, \varphi_f, \varphi_{fd}$ ,
- .4 levers of dynamic stability –  $e_{20}, e_{30}, e_{40}, e_{\varphi}$ .

3.2.1.5 The number of stability parameters which could be used as stability criteria should be, however, limited. Therefore, by analysing the parameters used in various national stability requirements, the Working Group on Intact Stability concluded the following eight parameters have to be left for further consideration:  $GM_0, GZ_{20}, GZ_{30}, GZ_m, \varphi_m, \varphi_v, \varphi_{fd}, e$ .

3.2.1.6 During the realization of paragraph 3.2.1.2.3 of the programme, a special form of casualty record was prepared and circulated amongst IMO Member States [IMO 1963]. It was requested that the form be filled in carefully with as many details of the casualty as possible. Altogether there were casualty records collected for 68 passenger and cargo ships and for 38 fishing vessels [IMO 1966, 1966a]. In a later period, some countries submitted further casualty records so that, in the second analysis that was performed in 1985, data for 93 passenger and cargo ships and for 73 fishing vessels were available [IMO 1985]. On the basis of the submitted data, tables of details of casualties were prepared.

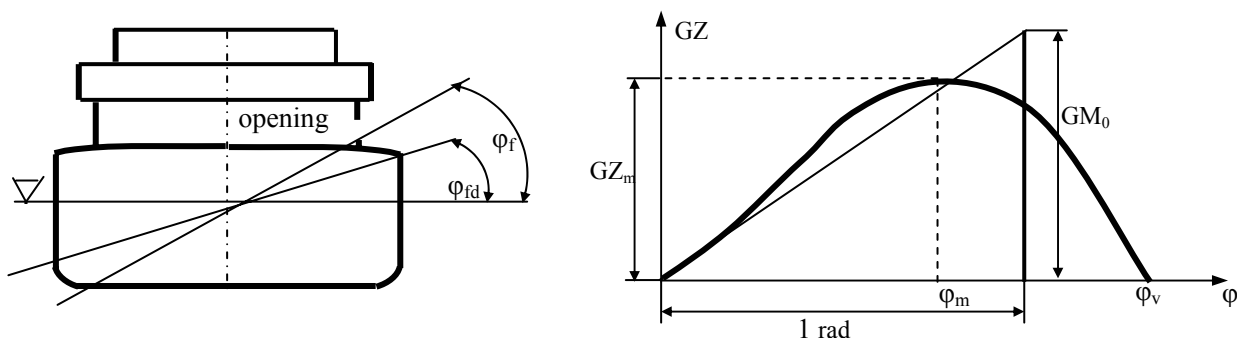

**Figure 1 – Explanation of righting levers and heeling angles**

3.2.1.7 Within paragraph 3.2.1.2.4 of the programme, data on stability characteristics for 62 passenger and cargo ships and for 48 fishing vessels, which were operated safely, were collected and for this purpose a special instruction containing detailed specifications for the manner how the stability information was to be submitted was developed. Also, for these ships, tables were prepared of stability parameters.

3.2.1.8 Paragraph 3.2.1.2.5 of the programme included analysis of the collected data, the results of which were submitted to IMO in several documents separately prepared for passenger and cargo ships and for fishing vessels [IMO 1965; 1966; 1966a; 1966b].

3.2.1.9 After IMO resolutions A.167(ES.IV) and A.168(ES.IV) had been adopted and further intact stability casualty data were collected, it was decided to repeat the analysis in order to find out if additional data might change conclusions drawn in the first analysis. This second analysis confirmed, in general, the results achieved in the first analysis [IMO 1985]. In the following text, the results of the second analysis that was based on the larger database are referred to.



3.2.1.10 The analysis performed consisted of two parts. In the first part, details relevant to casualties were evaluated, which allowed qualitative conclusions with regard to the circumstances of casualties to be developed and therefore the specification of general safety precautions. In the second part, stability parameters of ships reported as casualties were compared with those for ships which were operated safely. Two methods were adopted in this analysis. The first was identical with the method adopted by Rahola [Rahola 1939] and the second was the discrimination analysis. The results of the analysis of intact stability casualty data and of the first part of the analysis of stability parameters are included in paragraph 3.2.2.2. The results of the discrimination analysis are referred to in paragraph 3.2.2.3.

### 3.2.2 Results of the Analysis of Intact Stability Casualty Records and Stability Parameters

#### 3.2.2.1 Analysis of details relevant to the casualties

3.2.2.1.1 The evaluation of details relevant to the casualties is shown in Figures 2 to 7.

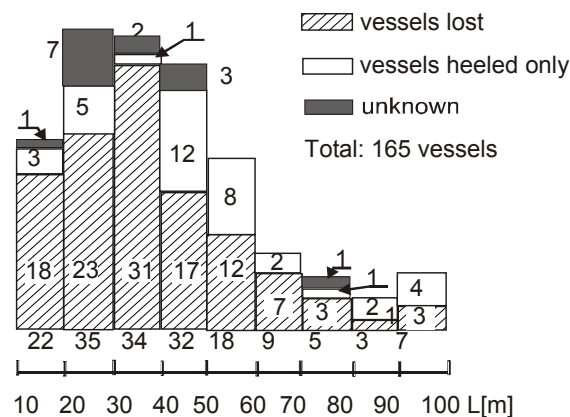

**Figure 2 – Distribution of length of capsized ships collated by IMO [1985]**

3.2.2.1.2 In all 166 casualties reported, the ships concerned were: 80 cargo ships, 1 cargo and passenger ship, 1 bulk carrier, 4 off-shore supply ships, 7 special service vessels, and 73 fishing vessels. Distribution of ship's length is shown in figure 2. It is seen that the majority of casualties occurred in ships of less than 60 m in length.

3.2.2.1.3 A great variety of cargoes were carried so that no definite conclusions could be drawn. It may be noted, however, that in 35 cases of the 80 cargo ships reported, deck cargo was present.

3.2.2.1.4 The result of the analysis of the location of the casualty is shown in Figure 3. It may be seen that the majority of casualties (72% of all casualties) occurred in restricted water areas, in estuaries and along the coastline. This is understandable because the majority of ships lost were small ships of under 60 m in length. From the analysis of the season when the casualty occurred (Figure 4) it may be seen that the most dangerous season is autumn (41% of all casualties).

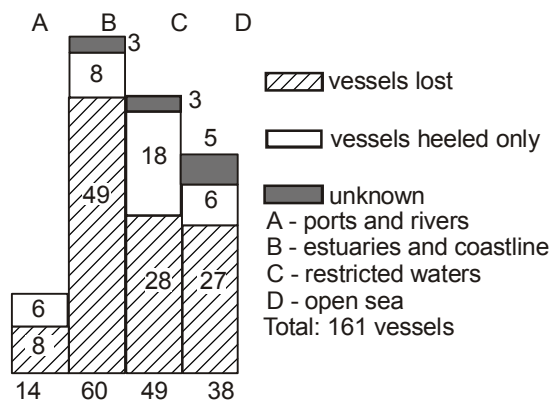

Figure 3 – Place of casualty [IMO 1985]

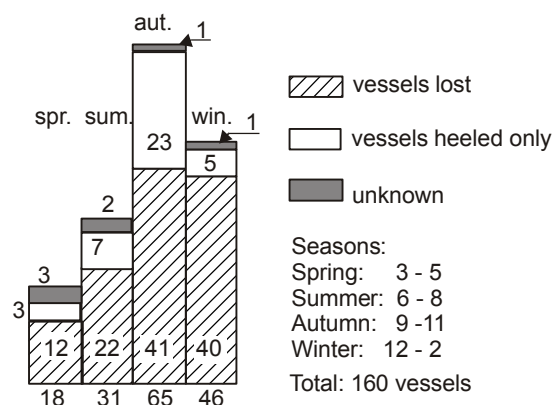

Figure 4 – Season of casualty [IMO 1985]

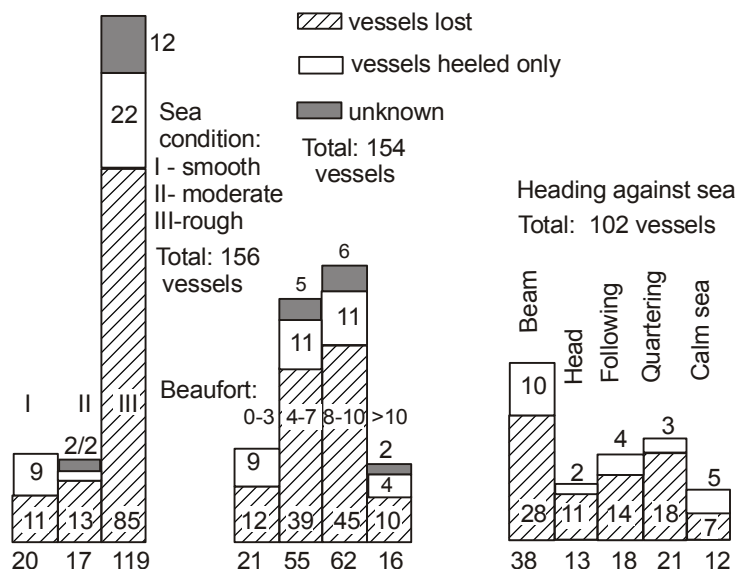

Figure 5 – Sea and wind condition during casualty [IMO 1985]

3.2.2.1.5 The result of the analysis of the weather conditions is shown in Figure 5. About 75% of all casualties occurred in rough seas at a wind force of between Beaufort 4 to 10. Ships were sailing most often in beam seas, less often in quartering and following seas.

3.2.2.1.6 The manner of the casualty was also analysed (Figure 6). It showed that the most common casualty was through gradual or sudden capsizing. In about 30% of casualties, ships survived the casualty and were heeled only.

3.2.2.1.7 In Figure 7 the results of the analysis of the age of ships are shown. No definite conclusions could be drawn from this analysis.

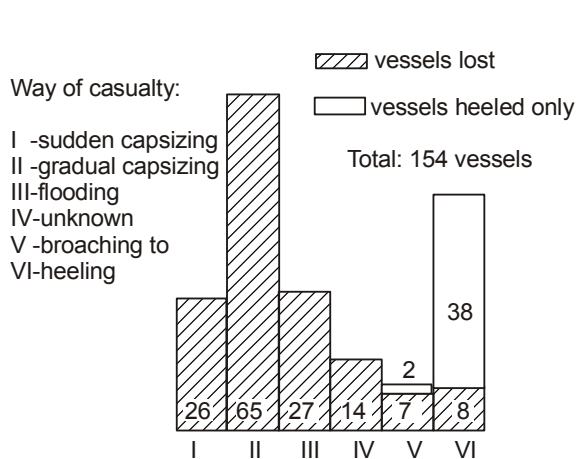

Figure 6 – Way of casualty [IMO 1985]

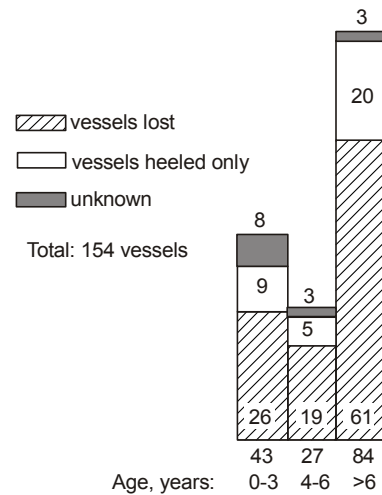

Figure 7 – Age of vessel during casualty [IMO 1985]

3.2.2.1.8 The distributions of stability parameters for ships' condition at time of loss are shown in Figures 8 to 14.

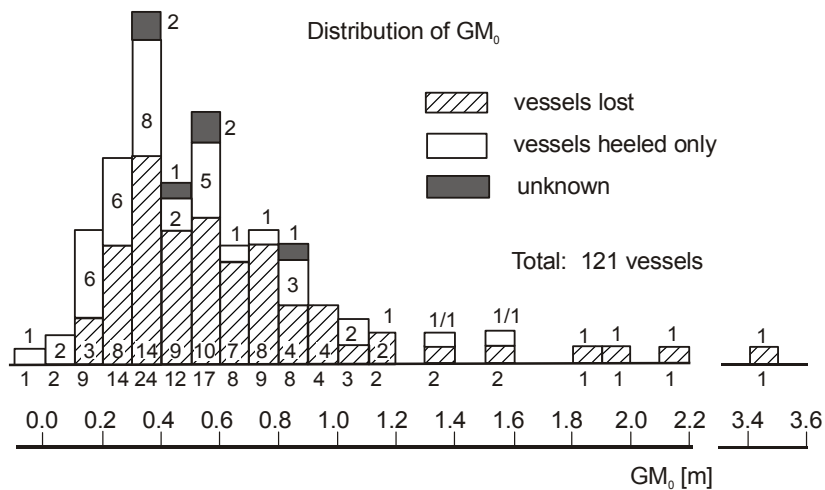

Figure 8 – Condition at time of casualty. Distribution of  $GM_0$  [IMO 1985]

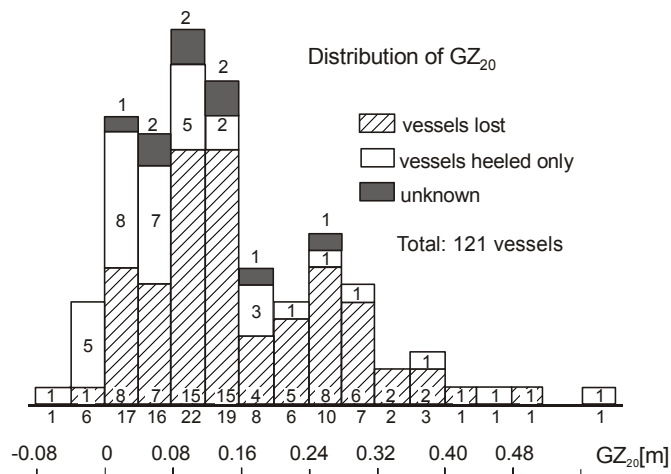

Figure 9 – Condition at time of casualty. Distribution of  $GZ_{20}$  [IMO 1985]

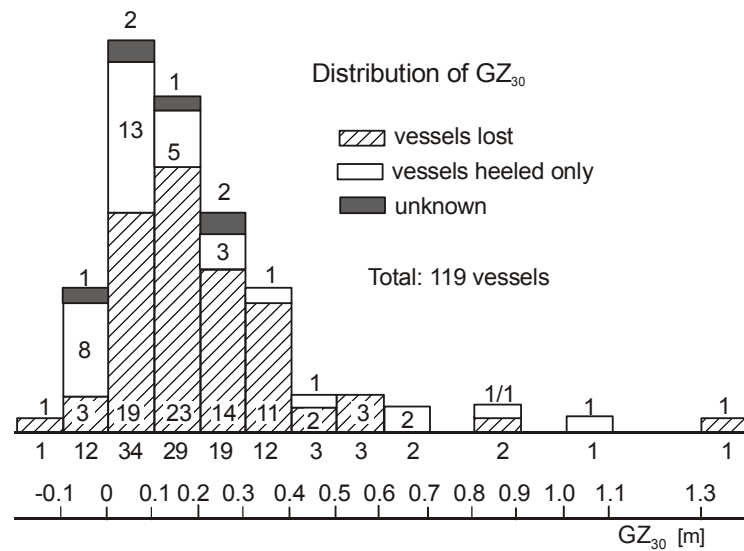

Figure 10 – Condition at time of casualty. Distribution of  $GZ_{30}$  [IMO 1985]

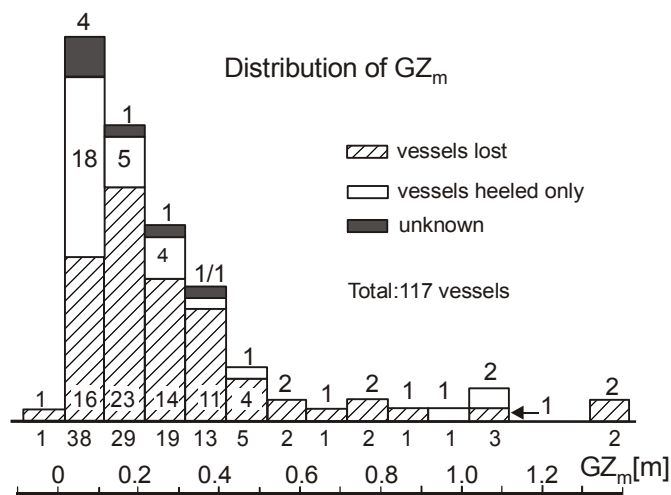

Figure 11 – Condition at time of casualty. Distribution of  $GZ_m$  [IMO 1985]

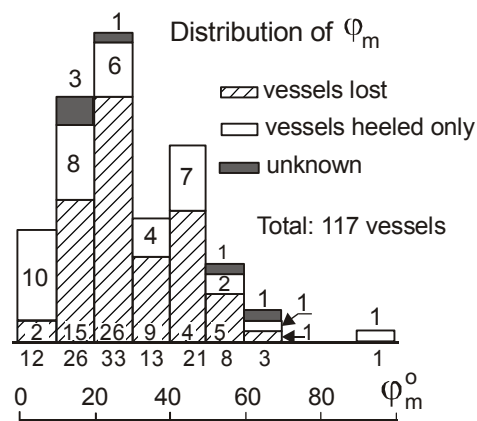

Figure 12 – Condition at time of casualty. Distribution of  $\phi_m$  [IMO 1985]

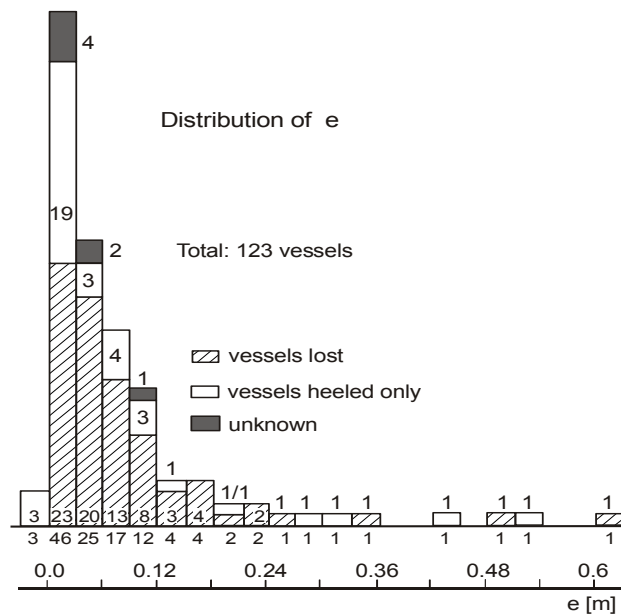

Figure 13 – Condition at time of casualty. Distribution of  $e$  [IMO 1985]

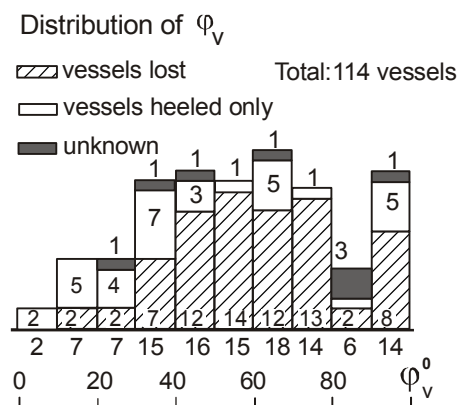

Figure 14 – Condition at time of casualty. Distribution of  $\phi_v$  [IMO 1985]

### 3.2.2.2 Analysis of stability parameters using Rahola method

3.2.2.2.1 The stability parameters for casualty condition were analysed by plotting in a similar manner, as was done by Rahola, together with parameters for ships operated safely for comparison.

3.2.2.2.2 The parameters chosen for analysis were  $GM_0$ ,  $GZ_{20}$ ,  $GZ_{30}$ ,  $GZ_{40}$ ,  $GZ_m$ ,  $e_{40}$ , and  $\phi_m$ . From the available data, histograms were prepared, where respective values of stability parameters for casualty condition were entered by starting with the highest value at the left of the vertical line (ordinate) down to the lowest value, and the values of the same parameter for safe ships were entered on the right side by starting from the lowest and ending with the highest value. Thus, at the ordinate, the highest value of the parameter for casualty condition is next to the lowest value of the parameter for the safe case. In Figure 15 an example diagram for righting levers comprising all ships analysed is shown. In the original analysis [IMO 1966, 1966a, 1985] diagrams were prepared separately for cargo and fishing vessels, but they are not reproduced here.

3.2.2.2.3 In the diagram (Figure 15), the values for casualty condition are shaded, only those that have to be specially considered due to exceptional circumstances were left blank. On the right side of the ordinate the areas above the steps were shaded in order to make a distinction between the safe and unsafe cases easier. The limiting lines or the imaginary static stability lever curves were drawn in an identical way as in the Rahola diagram. Percentages of ships in arrival condition, the respective stability parameters which are below the limiting lines are shown in table 1. The lower percentages mean in general that there is better discrimination between safe and unsafe conditions.

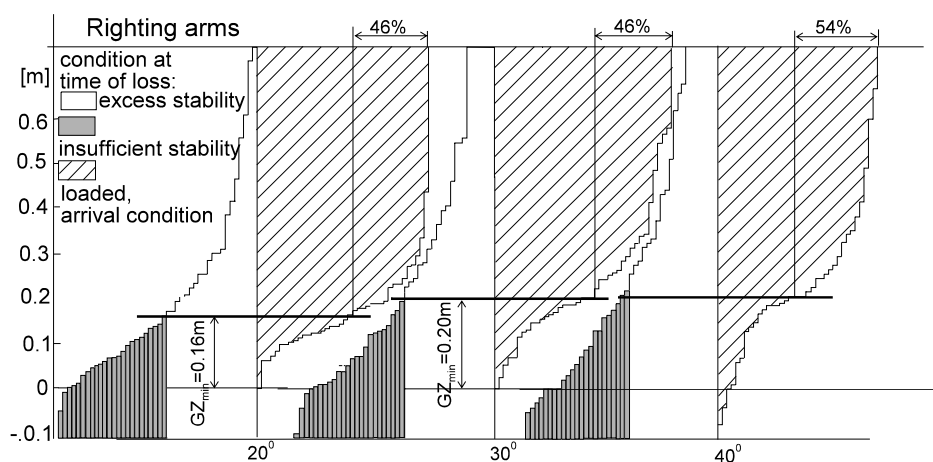

**Figure 15 – Plot of righting levers for ships at time of casualty. Cargo vessels only. [IMO 1966, 1985]**

**Table 1 – Percentages of ships below limiting line**

Stability parameter	Percentages		
	all ships	cargo	fishing
$GZ_{20}$	39	54	26
$GZ_{30}$	48	54	42
$GZ_{40}$	48	46	48
$e$	55	56	53

3.2.2.2.4 The type of analysis described above is not entirely rigorous; it was partly based on intuition and allows arbitrary judgement. Nevertheless, from the point of view of practical application, it provided acceptable results and finally was adopted as a basis for IMO stability criteria.

### 3.2.2.3 Discrimination Analysis

3.2.2.3.1 When two populations of data, as in this case, data for capsized ships and for ships considered safe, are available and the critical values of parameters from these two sets have to be obtained, the method of discrimination analysis may be applied.

3.2.2.3.2 The application of the discrimination analysis in order to estimate critical values of stability parameters were contained in a joint report by [IMO 1966, 1966a], and constituted the basis for development of IMO stability criteria along the previously described Rahola method.

3.2.2.3.3 In this investigation, discrimination analysis was applied independently to nine stability parameters. Using data from intact stability casualty records (group 1) and from intact stability calculations for ships considered safe in operation (group 2) the distribution functions were plotted, where for group 1 the distribution function  $F_1$  and for group 2 function  $(1 - F_2)$  were drawn. Practically, on the abscissa axis of the diagram, values for the respective stability parameter were plotted and the ordinates represent the number of ships in per cent of the total number of ships considered having the respective parameter smaller than the actual value for ships of group 1 and greater than the actual value for ships of group 2 considered safe.

3.2.2.3.4 The point of intersection of both curves in the diagram provides the critical value of the parameter in question. This value is dividing the parameters of group 1 and of group 2. In an ideal case, both distribution functions should not intersect and the critical value of the respective parameter is then at the point between two curves (see Figure 16).

3.2.2.3.5 In reality, both curves always intersect and the critical value of the parameter is taken at the point of intersection. At this point, the percentage of ships capsized having the value of the respective parameter higher than the critical value is equal to the percentage of safe ships having the value of this parameter lower than the critical value.

3.2.2.3.6 The set of diagrams was prepared in this way for various stability parameters based on IMO statistics for cargo and passenger ships and for fishing vessels. One of the diagrams is reproduced in Figure 17. It means that the probability of capsizing of a ship with the considered parameter higher than the critical value is the same as the probability of survival of a ship with this parameter lower than the critical value.

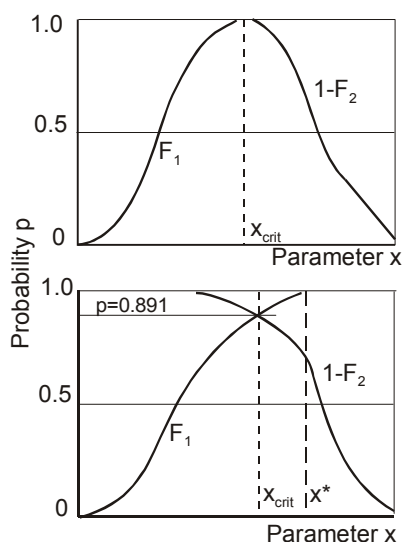

**Figure 16 – Estimation of critical parameter**

3.2.2.3.7 In order to increase the probability of survival, the value of the parameter should be increased, say up to  $x^*$  (Figure 16), at which the probability of survival (based on the population investigated) would be 100%. However, this would mean excessive severity of the criterion, which usually is not possible to adopt in practice because of unrealistic values of parameters

obtained in this way curves do intersect could be explained in two ways. It is possible that ships of group 2 having values of the parameter in question  $x < x_{crit}$  are unsafe, but they were lucky not to meet excessive environmental conditions which might cause capsizing. On the other hand, the conclusion could also be drawn that consideration of only one stability parameter is not sufficient to judge the stability of a ship.

3.2.2.3.8 The last consideration led to an attempt to utilize the IMO data bank for a discrimination analysis where a set of stability parameters was investigated [Krappinger and Sharma 1974]. The results of this analysis were, however, available after the SLF Sub-Committee had adopted criteria included in resolutions A.167(ES.IV) and A.168(ES.IV) and were not taken into consideration.

3.2.2.3.9 As can be seen from Figure 17, the accurate estimation of the critical values of the respective parameters is difficult because those values are very sensitive to the running of the curves in the vicinity of the intersection point, especially if the population of ships is small.

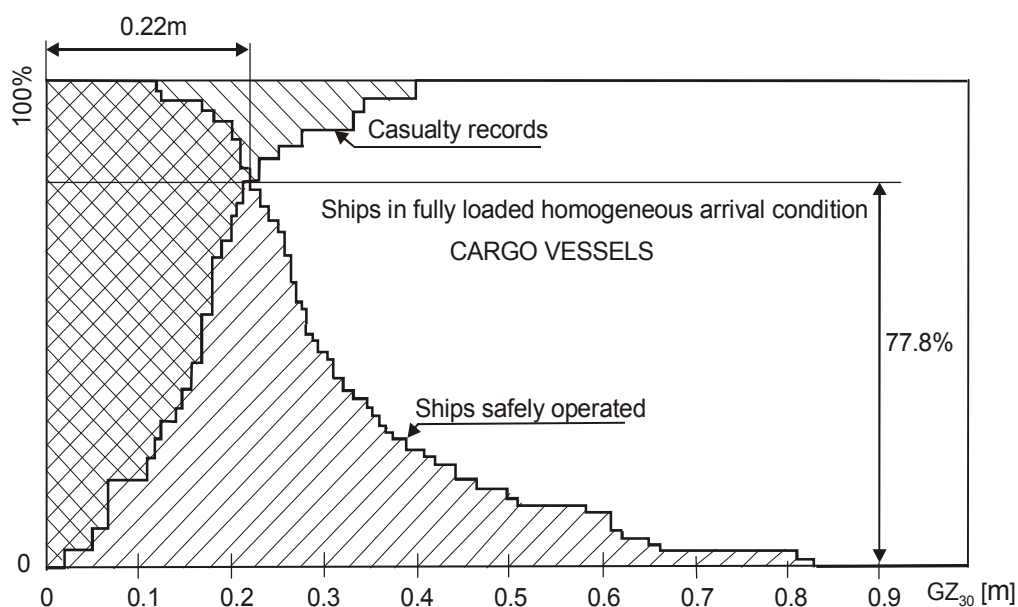

**Figure 17 – Discrimination analysis for parameter  $GZ_{30}$  [IMO 1965]**

#### 3.2.2.4 Adoption of the final criteria and checking the criteria against a certain number of ships

3.2.2.4.1 The final criteria, as they were evaluated on the basis of the diagrams, are prepared in the form as shown in Figures 15 and 17. The main set of diagrams did show righting lever curves (Figure 15), but diagrams showing distribution of dynamic stability levers were also included. Diagrams were prepared jointly for cargo and passenger vessels and for fishing vessels, except vessels carrying timber deck cargo. Sets of diagrams were also separately prepared for cargo ships and fishing vessels. Diagrams in the form as shown in Figure 17 were prepared separately for each stability parameter and separately for cargo and passenger ships and for fishing vessels.



3.2.2.4.2 After discussion by the Working Group on Intact Stability and the SLF Sub-Committee, the stability criteria were rounded off and finally adopted in the form as they appear in the resolutions A.167(ES.IV) and A.168(ES.IV).

3.2.2.4.3 In the original analysis the angle of vanishing stability was also included. However, due to the wide scatter of values of this parameter, it was not included in the final proposal.

3.2.2.4.4 As each criterion or system of criteria has to be checked against a sample of the population of existing ships, it was necessary to find the common basis for comparison results achieved with the application of different criteria. The most convenient basis for the comparison was the value of  $KG_{crit}$  that is the highest admissible value of  $KG$  satisfying the criterion or system of criteria, and the higher the value of  $KG_{crit}$ , the less severe the criterion.

3.2.2.4.5 As an example, criteria related to the righting lever curves could be written as:

$$GZ = KZ - KG \sin \varphi \quad (1)$$

and

$$KG = \frac{KZ(\Delta, \varphi) - GZ}{\sin \varphi} \quad (2)$$

3.2.2.4.6 If for  $GZ$  and  $\varphi$ , values of respective criterion are inserted, values of  $KG_{crit}$  for respective displacement are obtained. Then the curve  $KG_{crit} = f(\Delta)$  could be drawn.  $KG_{crit}$  could also be obtained graphically as shown in Figure 18. It is possible to calculate values  $KG_{crit}$  also for dynamic criteria, although the method is more complicated.

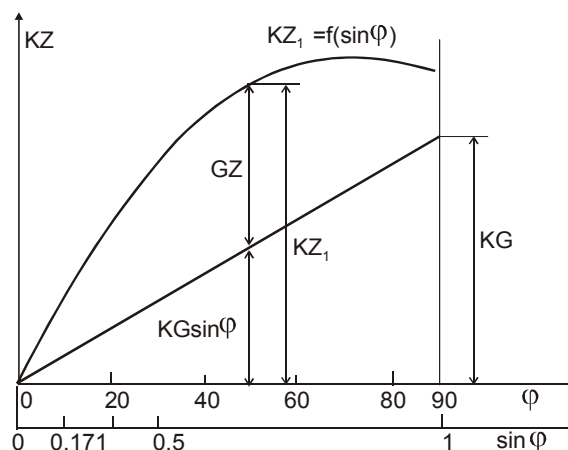

**Figure 18 – Graphical estimation of  $KG_{crit}$**

3.2.2.4.7 Figure 19 shows the results of calculations of  $KG_{crit}$  for a fishing vessel ([IMO 1966]). Curves  $KG_{crit} = f(\Delta)$  for 11 different criteria are plotted in the Figure. By having such curves for each individual criterion, it is easy to determine critical  $KG$  curve for a system of criteria by drawing envelope.

3.2.2.4.8 Curves for  $KG_{crit}$ , as shown in Figure 19, also allow conclusions to be drawn regarding the relative severity of various criteria or systems of criteria and to single out the governing one. If, in addition, actual values of  $KG$  for the particular ship are available, then it is possible to estimate whether the ship satisfies the criteria and which criterion leads to the condition most close to the actual condition. If it is assumed that ships in service are safe from the point of view of stability, it could be concluded which criterion or system of criteria fits in the best way without excessive reserve of stability.

3.2.2.4.9 With

$$k = \frac{KG_{actual}}{KG_{critical}}$$

a histogram of distribution of  $k$  is shown for the group of ships analysed (Figure 20).

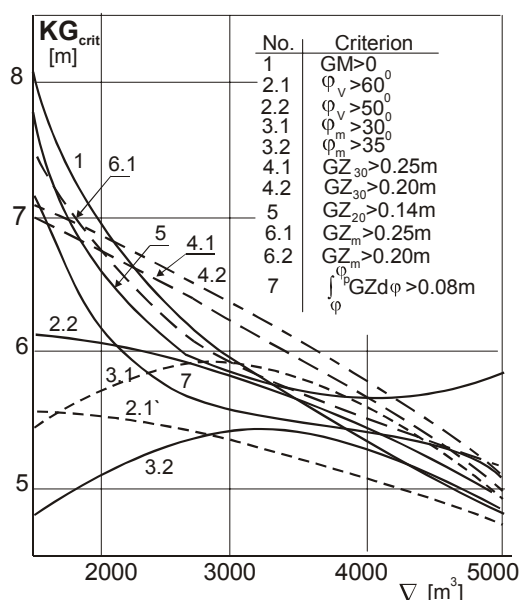

Figure 19 – Plot of the  $KG_{crit}$  curves for various criteria

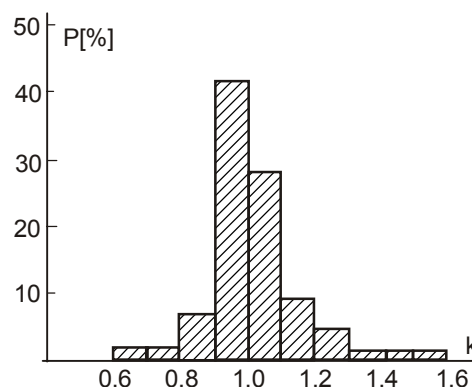

Figure 20 – Distribution of coefficient  $k$  for a group of ships analysed [Sevastianov 1968]

### 3.3 Background of the approximate formula for the minimum $GM_0$ for small fishing vessels (part B, paragraph 2.1.5.1 of the 2008 IS Code)

3.3.1 The approximate formula for the minimum metacentric height for small fishing vessels was developed using the method of regression analysis. In 1967 the Panel of Experts on Fishing Vessels Stability (PFV) of IMO recommended to develop an appropriate stability standard for small fishing vessels less than 30 m in length. The reason for this was the fact that for small fishing vessels quite often no drawings and stability data are available; therefore, the application of criteria of resolution A.168(ES IV) is not possible. It was proposed that a stability standard for those vessels could be developed in the form of a formula for  $GM_{crit}$  that could be compared with the actual  $GM_0$  estimated on the basis of the rolling test. The value of  $GM_{crit}$  should correspond to the criteria of resolution A.168(ES IV).

3.3.2 For the development of the appropriate formula, members of the Panel were requested to submit stability data for as many small fishing vessels as possible and also information regarding approximate formulae on  $GM_{crit}$  used in their countries, if any. Those formulae were later compared with the formulae developed by the regression analysis. The review of all approximate formulae revealed a rather wide scatter of values of  $GM_{crit}$ . This could be expected because it is obvious that the formulae do not take into account all parameters of the ship's hull that are important from the point of view of stability. Therefore, none of the formulae were adopted by IMO and it was decided to develop a new formula based on a regression analysis of a larger number of data for small fishing vessels.

3.3.3 The formula should provide results as close as possible to those provided by using IMO criteria included in resolution A.168(ES IV). As it would be impossible to take into account all criteria, it was decided that the representative criterion which should be satisfied was  $GZ_{30} = 0.20$  m.

3.3.4 Stability data was collected on 119 vessels of between 15 and 29 m in length and analysed [IMO 1968a].

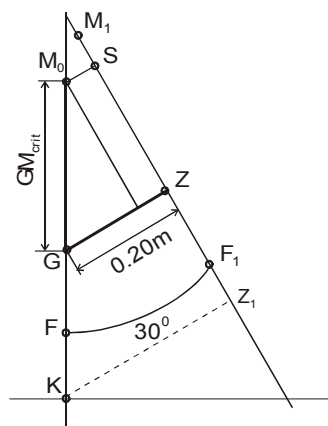

**Figure 21 – Relation between  $GM_{crit}$  and  $GZ = 0.20$ m**

3.3.5 As the condition for  $GM_{crit}$  is  $GZ_{30} = 0.2$  m, the following is valid (Figure 21):

$$GZ_{30} = GM_0 \sin 30^\circ + MS_{30} \quad (3)$$

then:

$$GM_{crit} = 0.40 - 2B \left( \frac{MS_{30}}{B} \right) \quad (4)$$

3.3.6 As  $MS_{30}/B$  depends only on geometrical parameters of the hull, this parameter might be used not only to evaluate  $GM_{crit}$  but also to compare different hull shapes from the stability point of view.

3.3.7 It is assumed that, in general,  $\frac{MS_{30}}{B} = f\left\{\frac{f}{B}, \frac{B}{D}, \frac{l_{sup}}{L}\right\}$  polynomial expressions of different

type were tested with coefficients evaluated by regression analysis. The evaluation of errors while estimating  $GM_{crit}$  of those expressions with respect to the actual  $GM_{crit}$  of the analysed vessels showed, as expected, that for about 50% of the vessels the calculated  $GM_{crit}$  was smaller than the actual value. For another 50% it was greater than the actual value (Figure 22a) with the distribution of errors considered acceptable. To increase the safety, it was then decided that the calculated values of  $GM_{crit}$  should be increased by a certain amount,  $C_{GM}$ , in order to achieve a situation where about 85% of vessels were on the safe side (Figure 22b). This supplementary  $C_{GM}$  was evaluated by an iteration process and it was determined that the proper value is  $C_{GM} = 0.1250$ .

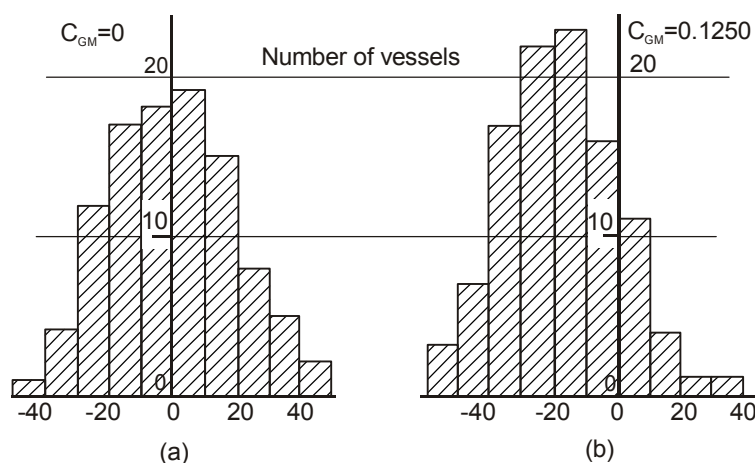

**Figure 22 – Distribution of errors in estimation of  $GM_{crit}$  for small fishing vessels**

3.3.8 The formula (4) was modified as follows:

$$GM_{crit} = 0.40 + C_{GM} - 2B \left( \frac{MS_{30}}{B} \right) \quad (5)$$

3.3.9 The final formula, as given in resolution A.207(VII), was:

$$GM_{crit} = 0.40 + C_{GM} - 2B \left[ a_0 + a_1 \left( \frac{f}{B} \right) + a_2 \left( \frac{f}{B} \right)^2 + a_3 \left( \frac{B}{T} \right) + a_4 \left( \frac{l_{sup}}{L} \right) \right] \quad (6)$$

where:

$C_{GM}$	=	0.1250	$a_2$	=	- 0.8340
$a_0$	=	- 0.0745	$a_3$	=	0.0137
$a_1$	=	0.3704	$a_4$	=	0.0321

### 3.4 References relating to paragraphs 3.1 to 3.3

- IMO (1963). "Intact stability casualty record", *Document IS II/12*.
- IMO (1964). "Report on the national requirements for intact stability of ships", *Document IS III/3*.
- IMO (1965). "Analysis of intact stability casualty records", *Documents IS IV/11 and IS IV/14*.
- IMO (1966). "Analysis of intact stability casualty records of cargo and passenger vessels", *Document IS VI/3*.
- IMO (1966a). "Analysis of intact stability record of fishing vessels", *Document PFV IV/2*.
- IMO (1966b). "Analysis of intact stability casualty records of fishing vessels", *Document PFV IV/2/Add 1*.
- IMO (1967). "Analysis of the application of various stability criteria of fishing vessels. Part II", *Document PFV VI/24*.
- IMO (1968). "Analysis of simplified formulae for judgement of stability of fishing vessels", *Document PFV VI/8*.
- IMO (1968a). "Simplified stability criteria for decked fishing vessels under 30 m in length", *Documents PFV VIII/12 and PFV IX/4/1*.
- IMO (1968b). "Recommendation on intact stability for passenger and cargo ships under 100 metres in length", *resolution A.167(ES.IV)*.
- IMO (1968c). "Recommendation on intact stability of fishing vessels", *resolution A.168(ES.IV)*.
- IMO (1977a). "Intact stability criteria", *Document STAB XX (unofficial)*.
- IMO (1985). "Analysis of intact stability casualty records", *Documents SLF 30/4/4 and SLF/38*.
- IMO (1988). "Intact stability. Report of the *ad hoc* Working Group", *Document SLF 33/WP.8*.
- IMO (1988a). "Report to the Maritime Safety Committee", *Document SLF 33/12*.
- IMO (1990). "Draft code on intact stability for all types of ships covered in IMO instruments", *Document SLF 34/3/7*.
- IMO (1993). "Code on intact stability for all types of ships", *resolution A.749(18)*.
- Jens, J., Kobylinski, L. (1982). "IMO activities in respect of international requirements for the stability of ships". *Second International Conference on stability of ships and ocean vehicles, STAB '82, Tokyo*.
- Kobylinski, L. (1989). "Code of stability for all types of ships based on system approach", *International Conference PRADS 89, Varna, Bulgaria*.
- Kobylinski, L.K., Kastner, S. (2003). "Stability and Safety of Ships. Vol. I: Regulation and Operation". *Elsevier Ocean Engineering Book Series, Vol.9, Elsevier*.
- Krappinger, O. and Sharma, S.D. (1974). "Sicherheit in der Schiffstechnik", *Transactions STG, Vol. 68*.
- Nadeinski, V.P. and Jens, J.E.L. (1968). "Stability of fishing vessels", *Transactions RINA*.
- Plaza, F., Petrov, A.A. (1986). "Further IMO activities in the development of international requirements for the stability of ships", *Third International Conference on stability of ships and ocean vehicles, STAB '86, Gdańsk*.
- Plaza, F., Semenov, V.Y. (1990). "Latest work of the International Maritime Organization related to stability of ships", *Fourth International Conference on stability of ships and ocean vehicles, STAB '90, Naples*.
- Rahola, J. (1935). "The judging of the stability of ships", *Transactions INA*.
- Rahola, J. (1939). "The judging of the stability of ships and the determination of the minimum amount of stability", *Ph.D. Thesis, Helsinki*.
- Thompson, G. and Tope, J.E. (1970). "International considerations of intact stability standards", *Transactions RINA, Vol. 112, pp. 43-67*.

### **3.5 Background of the severe wind and rolling criterion (weather criterion)**

#### **3.5.1 Introduction**

3.5.1.1 The severe wind and rolling criterion (weather criterion) is one of general provisions of the 2008 IS Code. This criterion was originally developed to guarantee the safety against capsizing for a ship losing all propulsive and steering power in severe wind and waves, which is known as a dead ship. Because of no forward velocity of ships, this assumes an irregular beam wind and wave condition. Thus operational aspects of stability are separated from this criterion, and are dealt with the guidance to the master for avoiding dangerous situation in following and quartering seas (MSC/Circ.707), in which a ship could capsize more easily than beam seas under some operational actions.

3.5.1.2 The weather criterion firstly appeared in the IMO instruments as Attachment No.3 to the Final Act of Torremolinos International Convention for the Safety of Fishing Vessels, 1977. During the discussion for developing the Torremolinos Convention, the limitation of the GZ curve criterion based on resolution A.168(ES.IV) was remarked; it is based on experiences of fishing vessels only in limited water areas and it has no way for extending its applicability to other ship types and other weather conditions. Thus, other than the GZ curve criterion, the Torremolinos Convention adopted the severe wind and rolling criterion including a guideline of calculation. This new provision is based on the Japanese stability standards for passenger ships (Tsuchiya, 1975; Watanabe *et al.*, 1956).

3.5.1.3 Then, a similar criticism to the GZ curve criterion for passenger and cargo ships, resolution A.167(ES.IV), was raised at IMCO. At least resolution A.167(ES.IV) was claimed to be applicable to ships of 100 m in length or below because of the limitation of statistical data source. As a result, a weather criterion was adopted also for passenger and cargo ships as well as fishing vessels of 45 m in length or over, as given in resolution A.562(14) in 1985. This new criterion keeps the framework of the Japanese stability standard for passenger ships but includes USSR's calculation formula for roll angle. For smaller fishing vessels, resolution A.685(17) in 1991 was passed. Here the reduction of wind velocity near sea surface is introduced reflecting USSR's standard. When the IS Code was established as resolution A.749(18) in 1993, all the above provisions were superseded.

#### **3.5.2 Energy Balance Method**

3.5.2.1 The basic principle of the weather criteria is energy balance between the beam wind heeling and righting moments with a roll motion taken into account. One of the pioneering works on such energy balance methods can be found in Pierrottet (1935) (Figure 23). Here, as shown in Figure 3.1, the energy required for restoring is larger than that required for the wind heeling moment. Since no roll motion is taken into account, a ship is assumed to suddenly suffer a wind heeling moment at its upright condition. This was later used in the interim stability requirements of the USSR and then Poland, Rumania, GDR and China (Kobylinski & Kastner, 2003).

3.5.2.2 In Japan the energy balance method is extended to cover a roll motion and to distinguish steady and gusty wind as shown in Figure 24. Then it is adopted as the basic principle of Japan's national standard (Watanabe *et al.*, 1956). The regulation of the Register of Shipping of the USSR (1961) also assumes initial windward roll angle as shown in Figure 24. The current IMO

weather criterion of chapter 2.3 of the IS Code, part A, utilizes the energy balance method adopted in Japan without major modification. Here we assume that a ship with a steady heel angle due to steady wind has a resonant roll motion in beam waves. Then, as a worst case, the ship is assumed to suffer gusty wind when she rolls toward windward. In the case of the resonant roll, roll damping moment and wave exciting moment cancel out. Thus, the energy balance between restoring and wind heeling energy can be validated around the upright condition. Furthermore, at the final stage of capsizing, since no resonance mechanism exists near the angle of vanishing stability, the effect of wave exciting moment could be approximated to be small (Belenky, 1993).

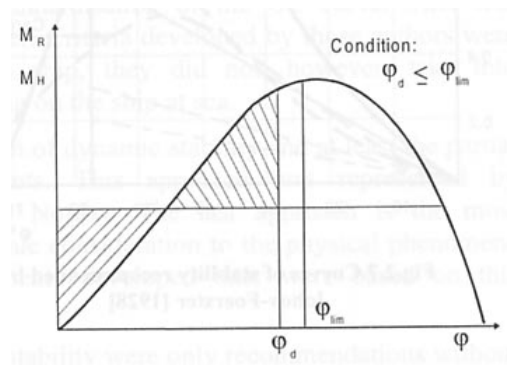

Figure 23 – Energy balance method used by Pierrottet (1935)

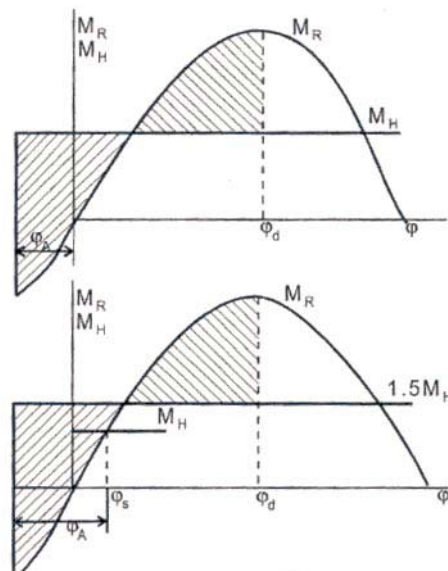

Figure 24 – Energy balance methods in standards of USSR (upper) and Japan (lower) (Kobylinski & Kastner, 2003)

### 3.5.3 Wind heeling moment

3.5.3.1 In the Japanese standard the steady heeling moment,  $M_w$ , is expressed as follows:

$$M_w = \frac{1}{2} \rho C_D A H_0 (H / H_0) V_w^2 \quad (1)$$

where:

- $\rho$  = air density
- $C_D$  = drag coefficient
- $A$  = lateral windage area above water surface
- $H$  = heeling lever
- $H_0$  = vertical distance from centre of lateral windage area to a point at one half the mean draught
- $V_w$  = wind velocity

3.5.3.2 Values of  $C_D$  obtained from experiments of passenger ships and train ferries ranges from 0.95 to 1.28. In addition, a wind tunnel test for a domestic passenger ship (Okada, 1952) shows that  $H/H_0$  is about 1.2. Considering these data, the value of  $C_D(H/H_0)$  was assumed to be 1.22 on average. These formula and coefficients were adopted also at IMO.

3.5.3.3 To represent fluctuating wind, gustiness should be determined. Figure 25 shows the ratio of gustiness measured in various stormy conditions. (Watanabe *et al.*, 1955). Here the maximum is 1.7 and the average is  $\sqrt{1.5} (\approx 1.23)$ . However, these were measured for about 2 hours of duration but capsizes could happen within half the roll natural period, say 3 to 8 seconds. In addition, reaction force could act on centre of ship mass because of such short duration. Therefore, in place of the maximum value, the average value of Figure 25 is adopted. This results in 1.5 as heeling lever ratio for gustiness as shown in the 2008 IS Code.

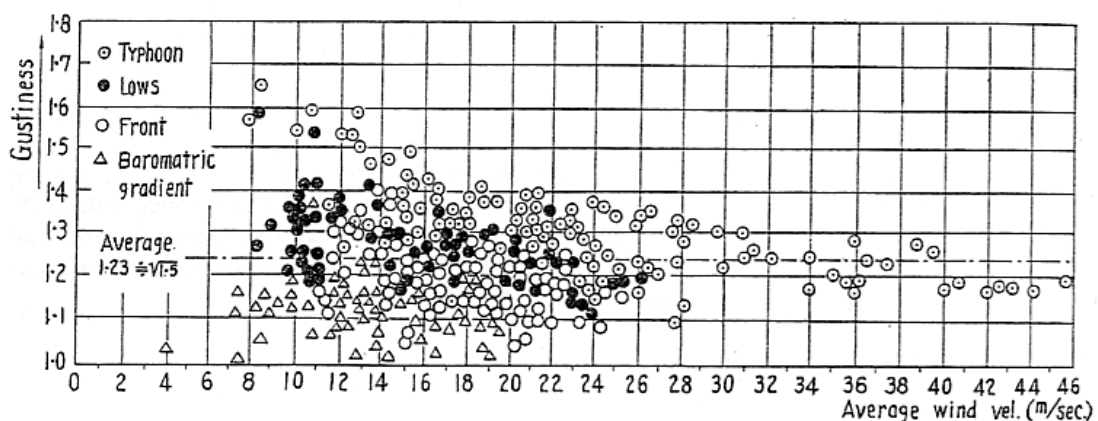

Figure 25 – Gustiness of measured sea wind (Watanabe *et al.*, 1956)



### 3.5.4 Roll angle in waves (Japanese Method)

In general, ship motion consists of surge, sway, heave, roll, pitch and yaw. In beam seas, however, only sway, heave and roll are dominant. Furthermore, the effect of heave on roll is negligibly small and coupling from sway to roll can be cancelled with roll diffraction moment (Tasai & Takagi, 1969). Therefore, the roll motion can be modelled without coupling from other motion modes if the wave exciting moment is estimated without wave diffraction. Consequently, considering nonlinear roll damping effect is taken into account, the amplitude of resonant roll in regular beam waves,  $\phi$  (degrees), can be obtained as follows:

$$\phi = \sqrt{\frac{\pi \Theta}{2N(\phi)}} \quad (2)$$

where:

- $\Theta (=180s)$  = maximum wave slope (degrees)
- $s$  = wave steepness
- $r$  = effective wave slope coefficient
- $N$  = Bertin's roll damping coefficient as a function of roll amplitude.

#### 3.5.4.1 Wave steepness

Based on observations at sea, Sverdrup and Munk (1947) published a relationship between wave age and wave steepness as shown in Figure 26. Here the wave age is defined with the ratio of wave phase velocity,  $u$ , to wind velocity,  $v$ , and wave height,  $H_w$ , means significant wave height.

If we use the dispersion relationship of water waves,  $u = \frac{gT}{2\pi}$ , this diagram can be converted to

that with wave period,  $T$ , as shown in Figure 27. Further, since the ship suffers a resonant roll motion, the wave period could be assumed to be equal to the ship natural roll period. Here it is noteworthy that the obtained wave steepness is a function of roll period and wind velocity. In addition, because of possible spectrum of ocean waves, regions for the maximum and minimum steepness are modified from the original data.

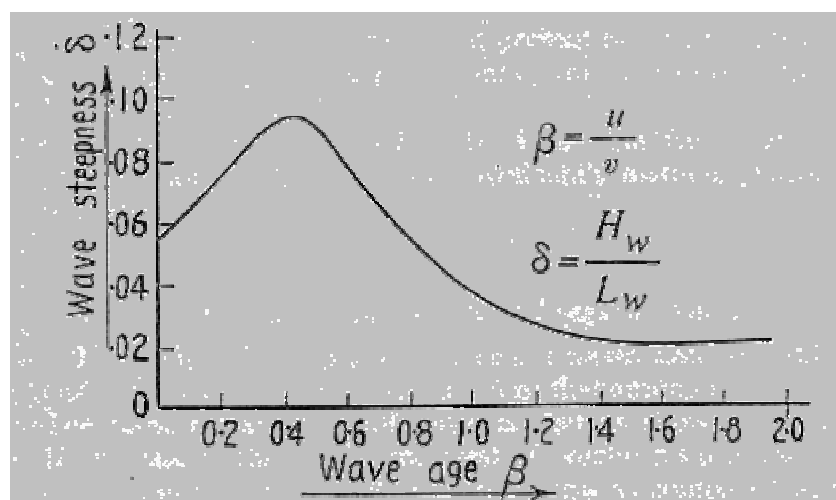
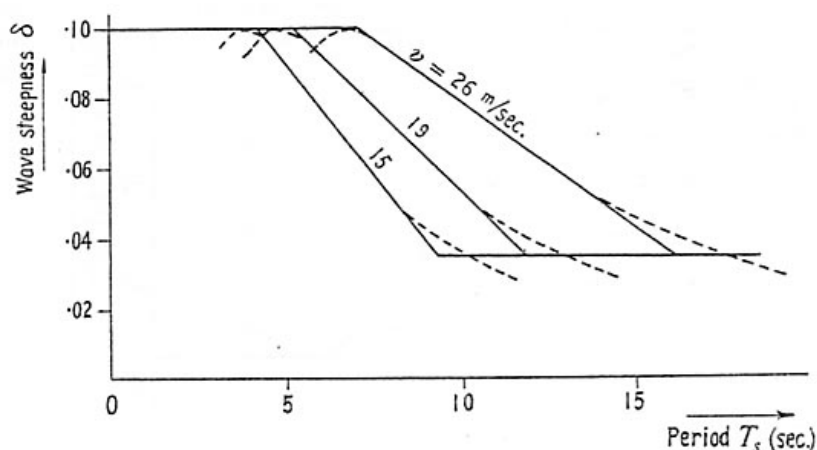

Figure 26 – Relationship between wave age and wave steepness (Sverdrup & Munk, 1947)



**Figure 27 – Relationship between roll period and wave steepness in Japanese criterion (Yamagata, 1959)**

### 3.5.4.2 Hydrodynamic coefficients

For using Equation (2), it is necessary to estimate the values of  $r$  and  $N$ . Since we should estimate wave exciting moment without wave diffraction due to a ship, it can be obtained by integrating undisturbed water pressure over the hull under calm water surface. Watanabe (1938) applied this method to several ships and developed an empirical formula, which is a function of wave length, VCG, GM, breadth, draught, block coefficient and water plane area coefficient. For simplicity sake, it is further simplified for 60 actual ships only as a function of VCG and draught shown in Figure 28. The formula used in the IMO weather criterion for  $r$  was obtained by this procedure.

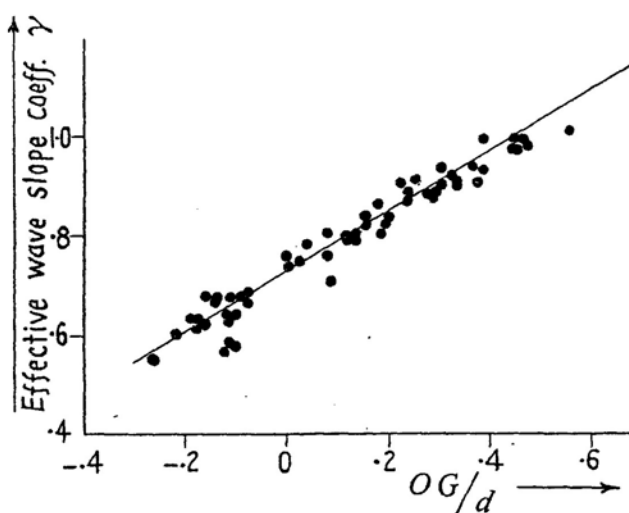

**Figure 28 – Effective wave slope coefficient: measurements (circles) and estimation (solid line) (Yamagata, 1959)**

For estimating the  $N$  coefficient, several empirical formulae were available. However, in the Japanese stability standards,  $N=0.02$  is recommended for a ship having bilge keels at the roll angle of  $20^\circ$ . Some evidence of this value can be found in Figure 29 (Matora, 1957).

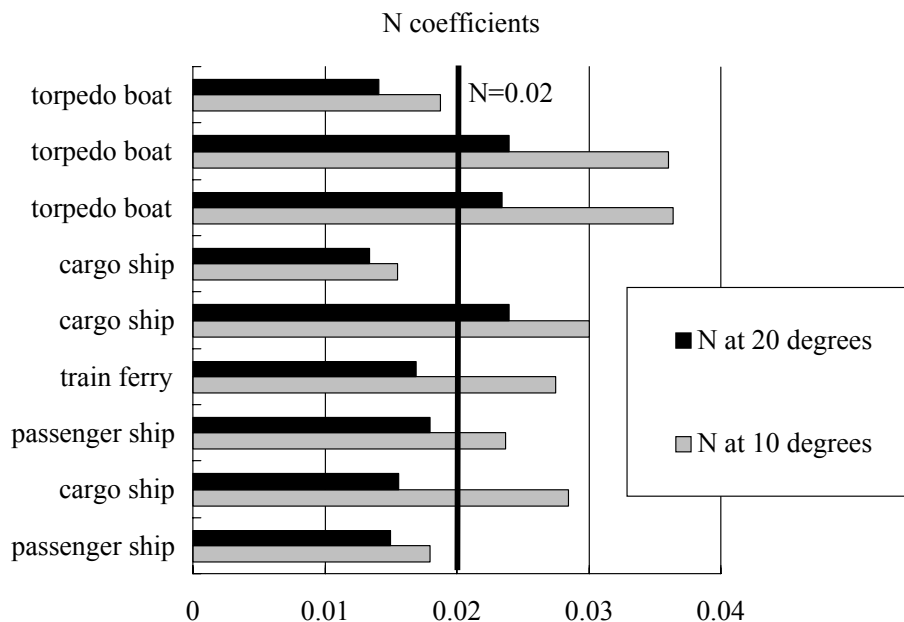

**Figure 29 – Example of *N* coefficients measured in model experiments**

#### 3.5.4.3 *Natural roll period*

For calculating the wave steepness, it is necessary to estimate the natural roll period for a subject ship. In the Japanese standard, the value measured with the actual ship is corrected with Kato's empirical formula (Kato, 1956). However, at the STAB Sub-Committee, this procedure was regarded as tedious and Japan was requested to develop a simple and updated empirical formula for the roll period. Thus the current formula was statistically developed by Morita, and is based on data measured from 71 full-scaled ships in 1982. As shown in Figure 30, all sampled data exist within  $\pm 7.5\%$  of error from Morita's formula. More precisely, the standard deviation of the error from the formula is 1.9%. Furthermore, sensitivity analysis of *C* on required GM indicated that even 20% error of *C* estimation results in only 0.04 m error of required GM calculation. Therefore, IMO concluded that this formula can be used for weather criteria.

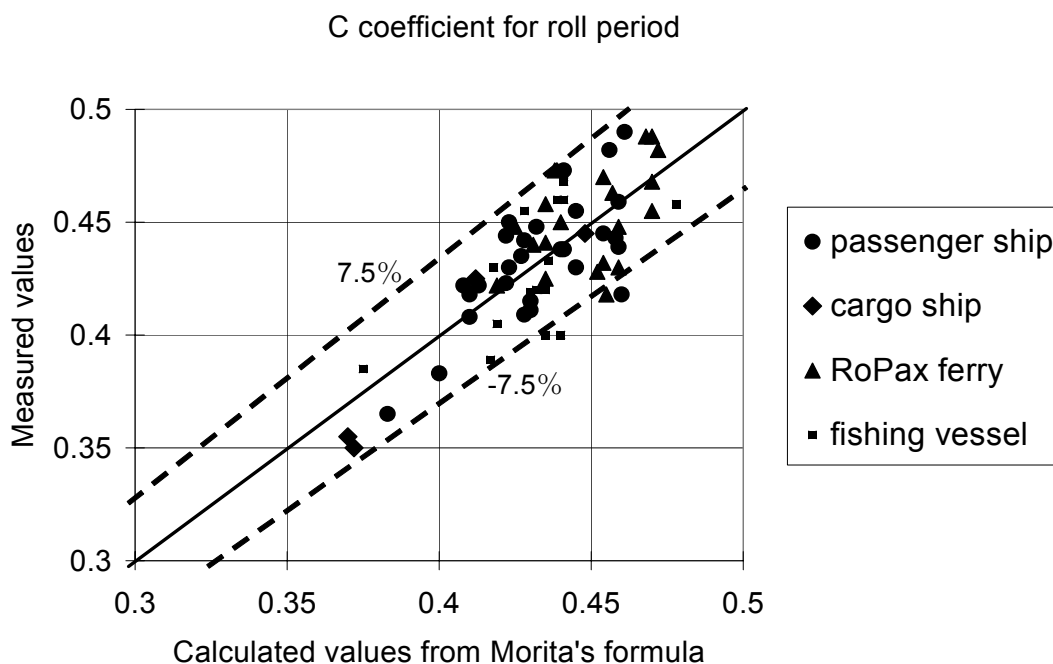

Figure 30 – Estimation accuracy for empirical formula for roll period

#### 3.5.4.4 Wave randomness

While the wave steepness obtained from Sverdrup-Munk's diagram is defined by the significant wave height in irregular waves, the resonant roll amplitude given by Equation (2) is formulated for regular waves. For filling the gap between two, the roll amplitude in irregular waves whose significant wave height and mean wave period are equal to height and period of regular waves was compared with the resonant roll amplitude in the regular waves. As shown in Figure 31, if we focus the maximum amplitude out of 20 to 50 roll cycles, an obtained reduction factor is 0.7.

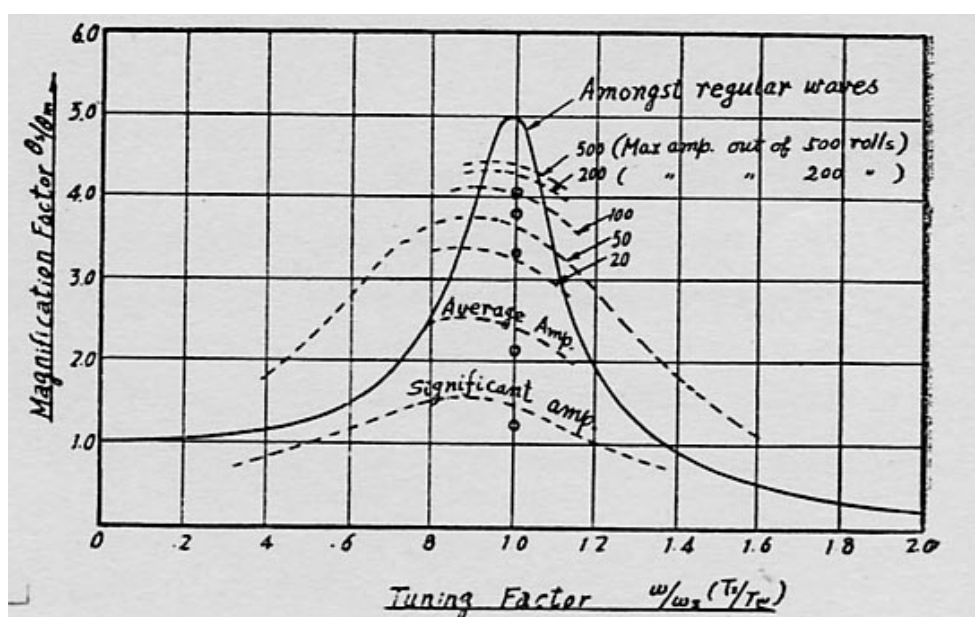
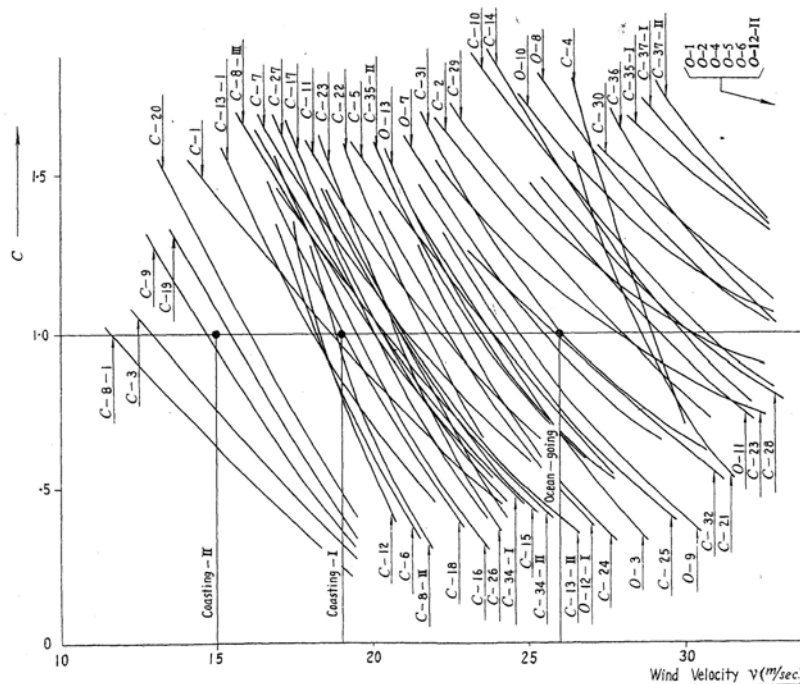

Figure 31 – Comparison of roll amplitude in regular and irregular waves (Watanabe *et al.*, 1956)

### 3.5.4.5 Steady wind velocity

As explained above, the Japanese weather criterion introduced probabilistic assumptions for determining gust and roll in irregular waves. These make final probabilistic safety level unclear. Possible estimation error for wind heel lever coefficient, roll damping coefficient, effective wave slope coefficient, natural roll period and wave steepness added uncertainty to the required safety level. Therefore, Japan carried out test calculations for 50 ships, which include 13 ocean going ships as shown in Figure 32. Based on these calculated outcomes, the steady wind velocity was determined to distinguish ships having insufficient stability from other ships. In other words, for ships having insufficient stability the energy balance should not be obtained with the above procedure. As a result, the wind velocity for ocean going ships is determined as 26 m/s. Here a sunken torpedo boat (0-12-I), a sunken destroyer (0-13) and three passenger ships having insufficient stability (0-3, 7, and 9) are categorized as unsafe and 2 cargo ships, 3 passenger ships and 3 larger passenger ships are done as safe. It is noteworthy here that 26 m/s of wind velocity is only obtained from casualty statistics for ships and is not directly obtained from actual wind statistics. IMO also adopted 26 m/s as critical wind velocity. If we substitute  $V_w=26$  m/s to Equation (1), the wind pressure in the current IS Code is obtained.



**Figure 32 – Results of test calculations for determining steady wind velocity. Relation between wind velocity and the b/a factor for various sample ships (Watanabe *et al.*, 1956)**

### 3.5.4.6 Rolling in waves (USSR's method)

In the stability standard of USSR (USSR, 1961), the maximum roll amplitude of 50 roll cycles is estimated as follows:

$$\phi_R = kX_1X_2\phi_A \quad (3)$$

Here  $k$  is a function of bilge keel area,  $X_1$  is a function of  $B/d$ ,  $X_2$  is a function of the block coefficient and  $\phi_A$  is roll amplitude of the standard ship, which is shown in Figure 33. This formula was developed by systematic calculations for a series of ships utilizing the transfer function and wave spectrum (Kobylinski & Kastner, 2003).

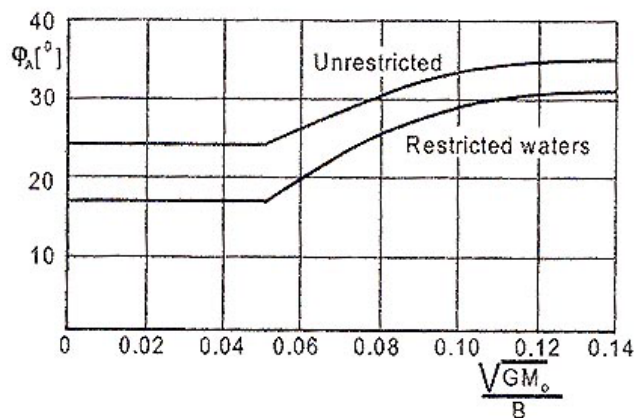

Figure 33 – Standard roll amplitude in USSR's criterion (USSR, 1961)

As mentioned earlier, IMO decided to partly use this USSR's roll formula together with the Japanese criterion. This is because the USSR's formula depends on hull forms for estimating roll damping while the Japanese does not. The proposed formula is as follows:

$$\phi_1(\text{degrees}) = C_{JR} k X_1 X_2 \sqrt{rs} \quad (4)$$

Here  $C_{JR}$  is a tuning factor for keeping the safety level of the new criterion as the same as the Japanese domestic standard. To determine this factor, member states of a working group of STAB Sub-Committee executed test calculations of Japanese and new formulations for many ships. For example, Japan (1982) executed test calculation for 58 ships out of 8,825 Japanese flagged-ships larger than 100 gross tonnage in 1980. These include 11 cargo ships, 10 oil tankers, 2 chemical tankers, 5 liquid gas carriers, 4 container ships, 4 car carriers, 5 tug boats and 17 passenger or RoPax ships. As a result, IMO concluded that  $C_{JR}$  should be 109.

### 3.6 References relating to paragraph 3.5

- Belenky, V.L. (1993). Capsizing Probability Computation Method, Journal of Ship Research, 37(3): 200-207.
- Japan (1982). Weather Criteria, Results on Japanese Ships, SLF/7.
- Kato, H. (1956). On a Method for Calculating an Approximate Value of the Rolling Period of Ships, Journal of Society of Naval Architects of Japan, Vol. 89.
- Kobylinski, L.K. and S. Kastner (2003). Stability and Safety of Ships, Elsevier (Oxford, UK), Vol. 1.
- Motora, S. (1957). Ship Dynamics, Kyoritsu Publications (Tokyo).
- Okada, S. (1952). On the Heeling Moment due to Wind Pressure on Small Vessels, Journal of Society of Naval Architects of Japan, Vol. 92: 75-81.
- Pierrote, E. (1935). A Standard of Stability for Ships, Transaction of the Institution of Naval Architects, p. 208.

- Sverdrup, H.U. and W.H. Munk (1947). Wind, Sea and Swell, Theory of Relations for Forecasting, Hydrographic Office Publication No.601.
- Tasai, F. and M. Takagi (1969). Theory and Calculation Method for Response in Regular Waves, Seakeeping Symposium, Society of Naval Architects of Japan, p.40.
- Tsuchiya, T. (1975). An Approach for Treating the Stability of Fishing Boats, Proceedings of International Conference on Stability of Ships and Ocean Vehicles, University of Strathclyde, 5.3:1-9.
- USSR (1961). Standards of Stability of Sea-Going Vessels and Coasters, Register of Shipping of the USSR, Mosrskoi Transport, Moscow. Also available in IMCO STAB/77, USSR (1979)
- Watanabe, Y., (1938). Some Contributions to the Theory of Rolling, Transaction of the Institution of Naval Architects, 80:408-432.
- Watanabe, Y. *et al.* (1955). Report of the Ocean Wind about Japan on the Naval-Architectural Point of View., Journal of Society of Naval Architects of Japan, Vol. 96: 37-42.
- Watanabe, Y. *et al.* (1956). A Proposed Standard of Stability for Passenger Ships (Part III: Ocean-going and Coasting Ships), Journal of Society of Naval Architects of Japan, Vol. 99: 29-46.
- Yamagata, M. (1959). Standard of Stability Adopted in Japan, Transaction of the Institution of Naval Architects, 101:417-443.

## CHAPTER 4 – GUIDANCE FOR THE APPLICATION OF THE 2008 IS CODE

### 4.1 Criteria regarding righting lever curve properties

For certain ships the requirement contained in paragraph 2.2.3 of part A of the Code may not be practicable. Such ships are typically of wide beam and small depth, indicatively  $B/D \geq 2.5$ . For such ships Administrations may apply the following alternative criteria:

- .1 the maximum righting lever (GZ) should occur at an angle of heel not less than  $15^\circ$ ; and
- .2 the area under the curve of righting levers (GZ curve) should not be less than 0.070 metre-radians up to an angle of  $15^\circ$  when the maximum righting lever (GZ) occurs at  $15^\circ$  and 0.055 metre-radians up to an angle of  $30^\circ$  when the maximum righting lever (GZ) occurs at  $30^\circ$  or above. Where the maximum righting lever (GZ) occurs at angles of between  $15^\circ$  and  $30^\circ$ , the corresponding area under the righting lever curve should be:

$$0.055 + 0.001 (30^\circ - \varphi_{\max}) \text{ metre-radians}^*$$

---

\*  $\varphi_{\max}$  is the angle of heel in degrees at which the righting lever curve reaches its maximum.